

# BENCH INSTRUCTIONS

BC2080  
BC2081  
BC2082  
BC2083  
BC2084

REV# 3  
3/21/2018

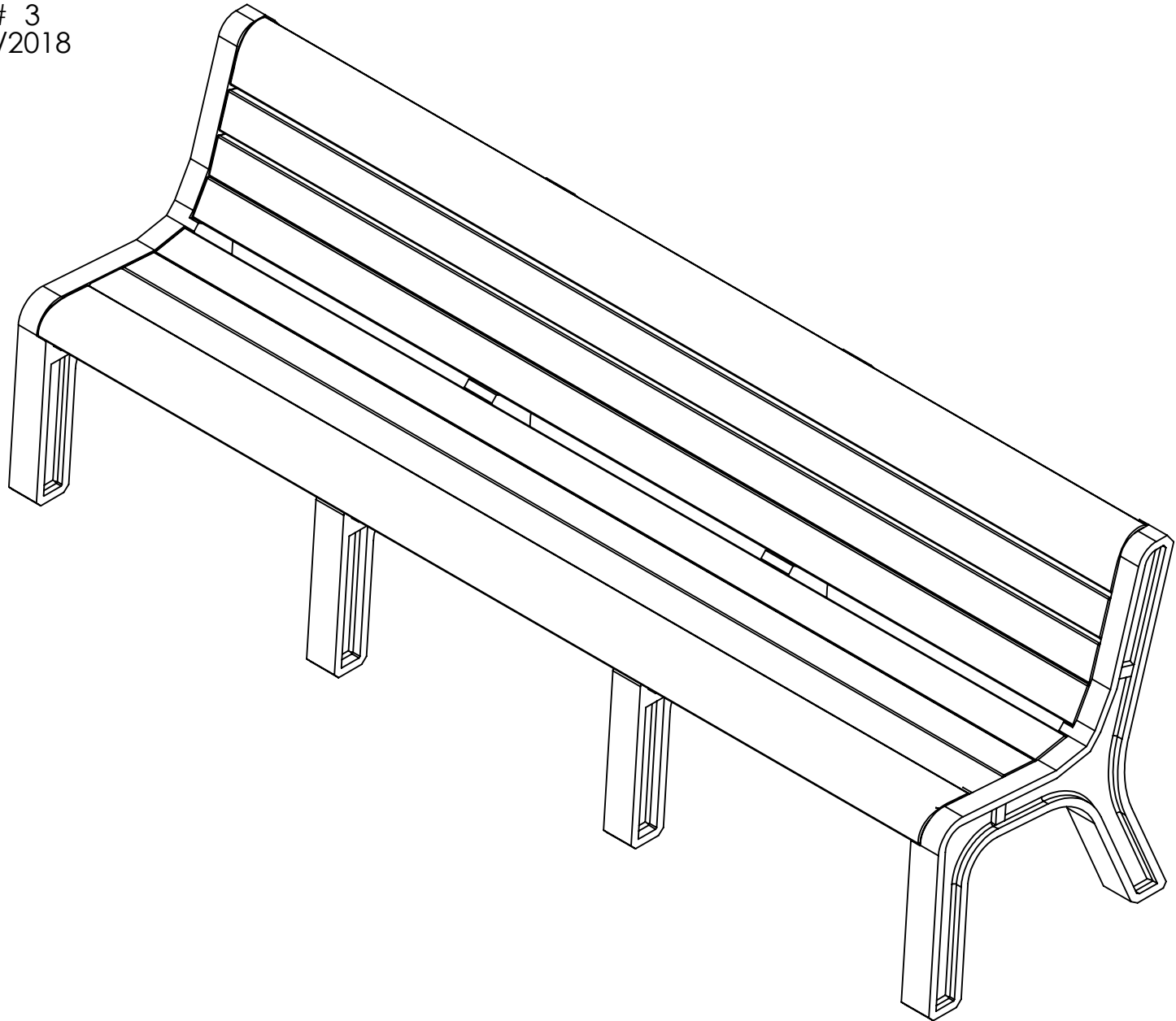

# BENCH INSTRUCTIONS

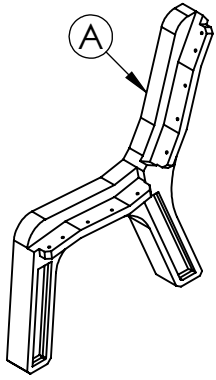

1  
LEFT SIDE  
BENCH END  
PRI7209L

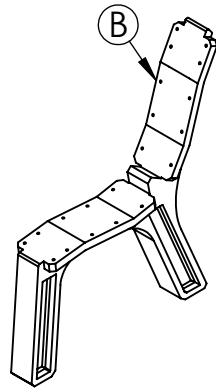

2  
CENTER  
BENCH END  
PRI7209C

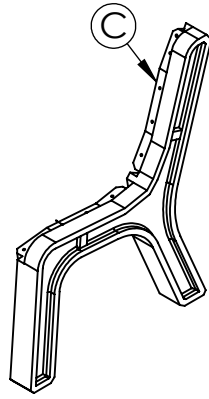

1  
RIGHT SIDE  
BENCH END  
PRI7209R

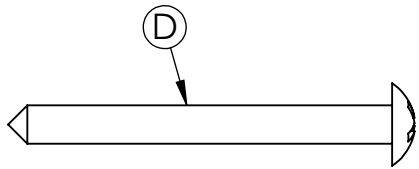

60  
#12 X 2" PAN HEAD SCREWS  
SMPP012C200A188

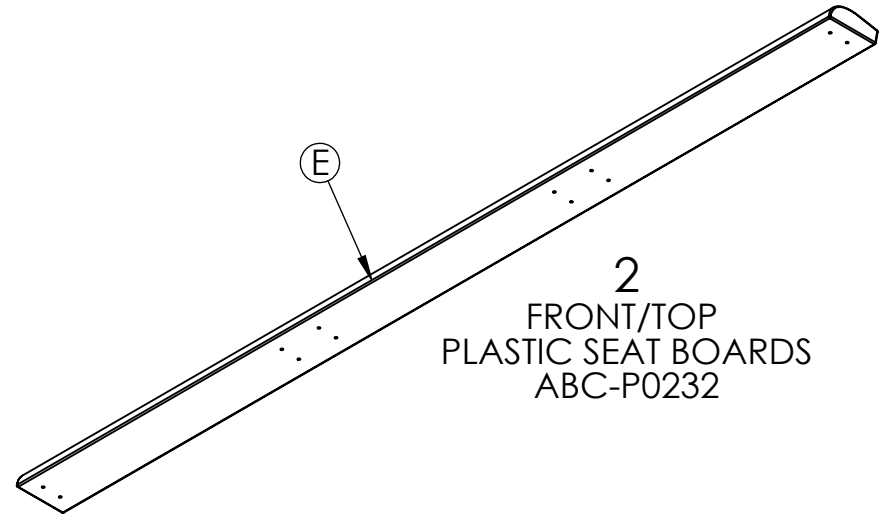

2  
FRONT/TOP  
PLASTIC SEAT BOARDS  
ABC-P0232

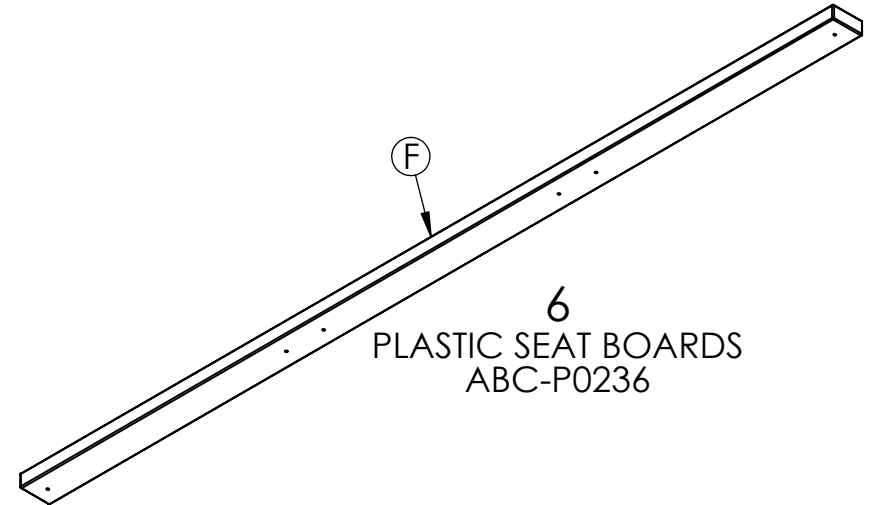

6  
PLASTIC SEAT BOARDS  
ABC-P0236

## REQUIRED TOOLS (NOT INCLUDED)

- POWER DRILL
- #2 PHILLIPS BIT

NOTE: IT IS IMPORTANT TO KEEP ALL SCREWS LOOSE DURING ASSEMBLY UNTIL ENTIRE BENCH IS ASSEMBLED

**HARDWARE &  
TOOLS REQUIRED  
FOR ASSEMBLY**

**2/6**

# BENCH INSTRUCTIONS

## STEP 1 Seat Assembly

- Lay Left Bench End (A) and Right Bench End (C) on its back with the front legs pointing up
- Lay a Plastic Seat Board (F) over the bench ends (A & C) closest to the rear leg on the seat
- Align the marks in the Plastic Seat Board (F) with the predrilled holes in the Bench Ends (A & C)
- Secure the Plastic Seat Board (F) with the #12 x 2 screws (D)
- Repeat for 2 more Plastic Seat Boards (F) starting at the rear and working toward the front

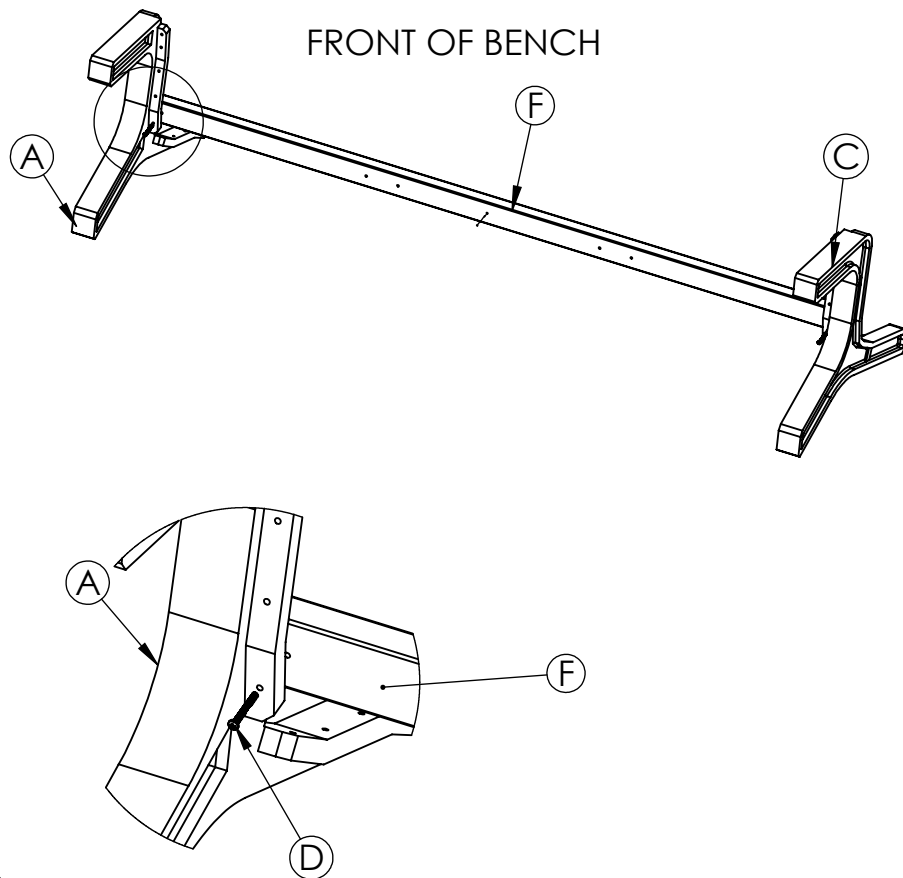

## STEP 2 Seat Assembly

- With the bench still on its back, lay the Center Bench End (B) onto Plastic Seat Boards (F)
- Align the marks in the Plastic Seat Board (F) with the predrilled holes in the Center Bench End (B)
- Secure the three Plastic Seat Boards (F) with the #12 x 2 screws (D) to the Center Bench End (B)

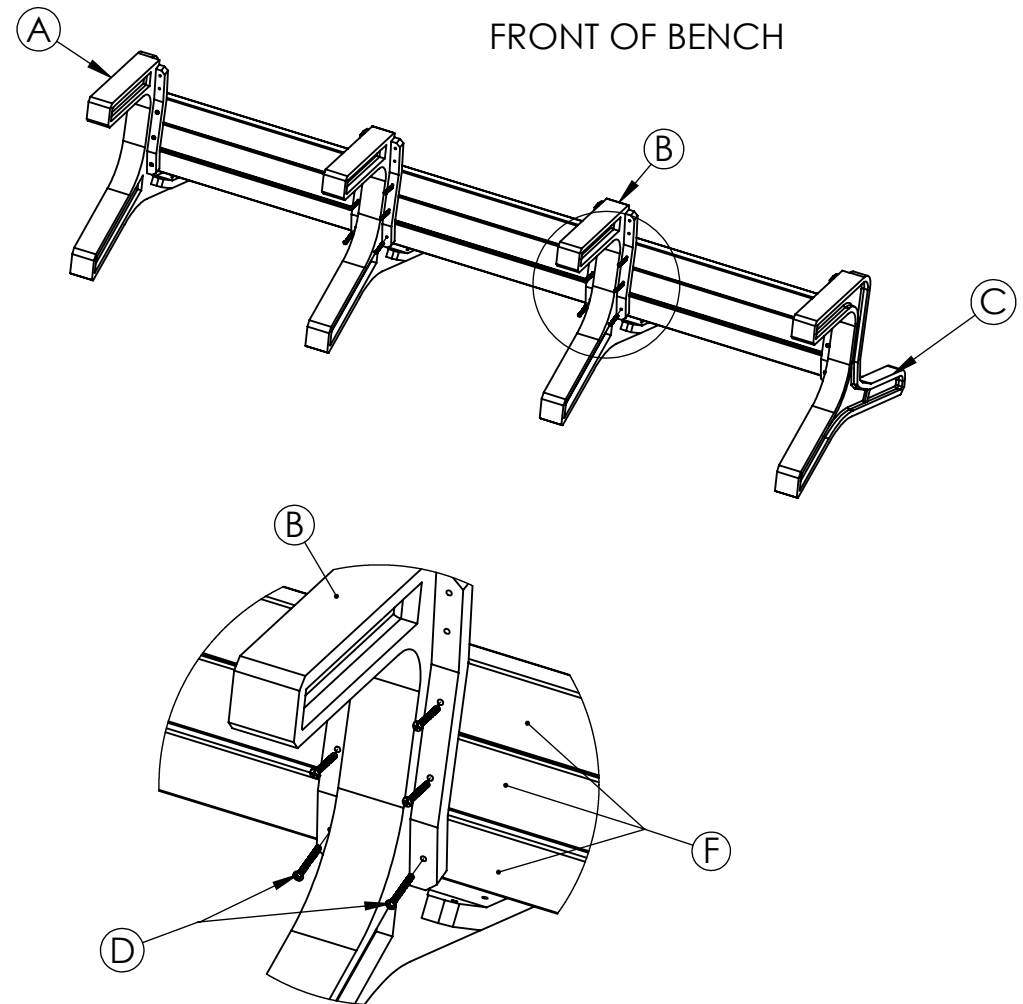

# BENCH INSTRUCTIONS

## STEP 3 Seat Assembly

- With the bench still on its back, lay the Front/Top Plastic Seat Board (E) onto the Bench Ends (A,B,C)
- Align the marks in the Plastic Seat Board (E) with the predrilled holes in the Bench Ends (A,B,C)
- Secure the three Plastic Seat Boards (F) with the #12 x 2 screws (D) to the Bench Ends (A,B,C)

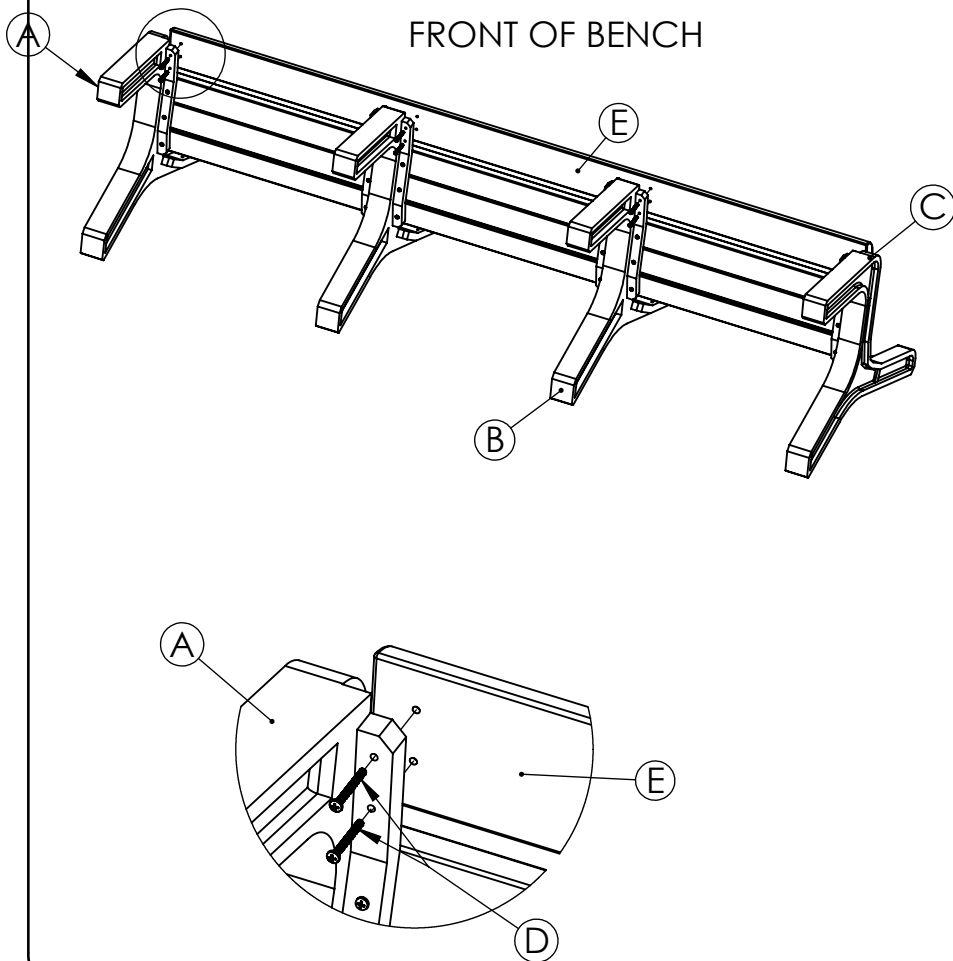

## STEP 4 Back Assembly

- Turn bench upright
- Lay a Plastic Seat Board (F) over the bench ends (A,B,C) closest to the seat
- Align the marks in the Plastic Seat Board (F) with the predrilled holes in the Bench Ends (A,B,C)
- Secure the Plastic Seat Board (F) with the #12 x 2 screws (D)
- Repeat for 2 more Plastic Seat Boards (F) starting at the seat and working toward the top

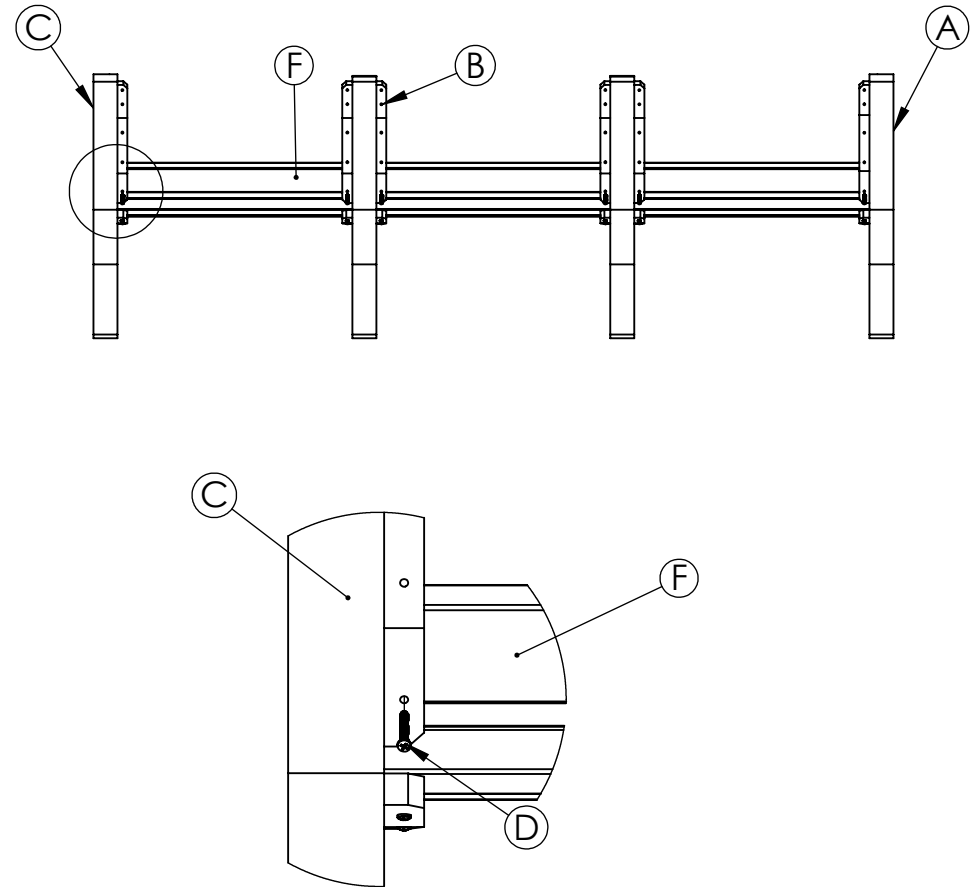

# BENCH INSTRUCTIONS

## STEP 5 Back Assembly

- Lay a Front/Top Plastic Seat Board (E) over the bench ends (A,B,C) at the top of the bench
- Align the marks in the Front/Top Plastic Seat Board (F) with the predrilled holes in the Bench Ends (A,B,C)
- Secure the Front/Top Plastic Seat Board (F) with the #12 x 2 screws (D)

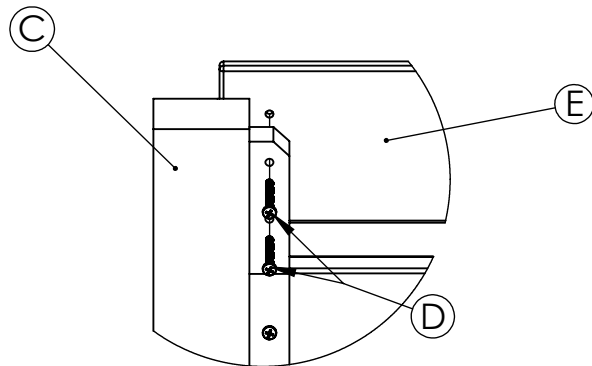
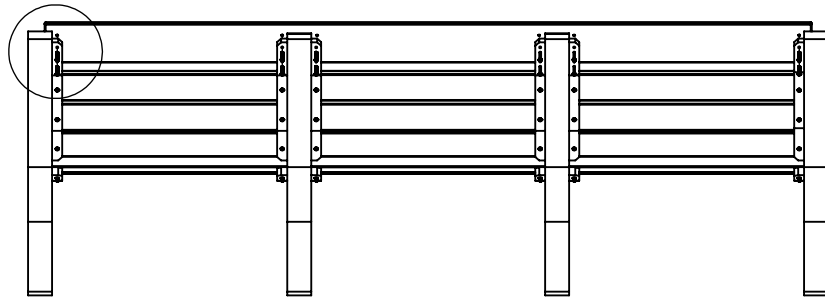

**NOTE:** THERE IS APPROXIMATELY  
A 0.5" GAP BETWEEN  
THE TOP THREE BOARDS

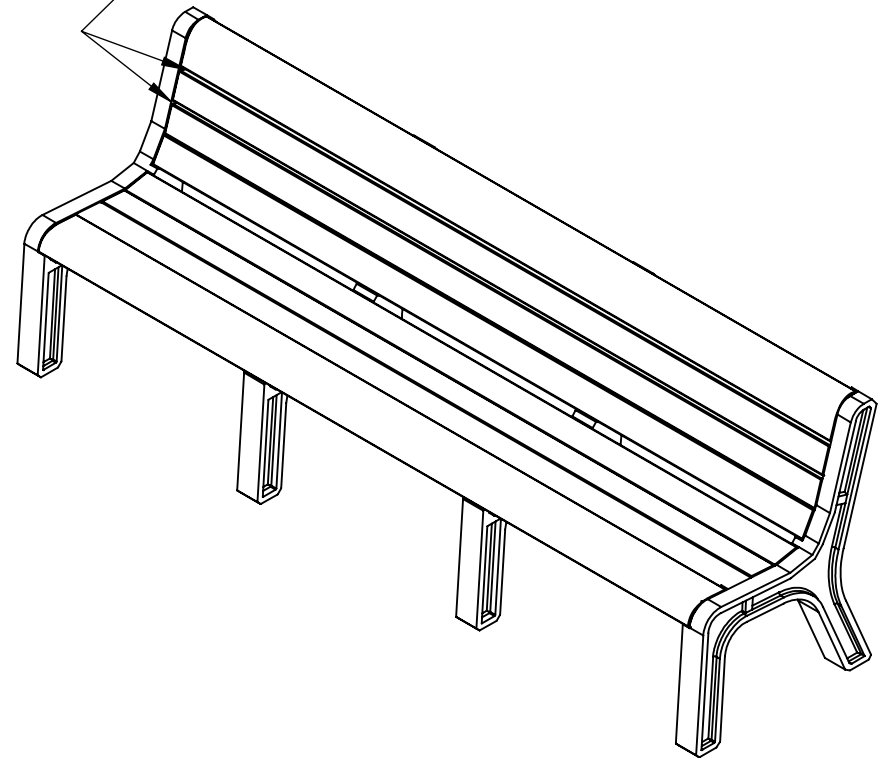

# BENCH SPECIFICATIONS

REV# 3  
3/21/2018

BC2080  
BC2081  
BC2082  
BC2083  
BC2084

### TOP

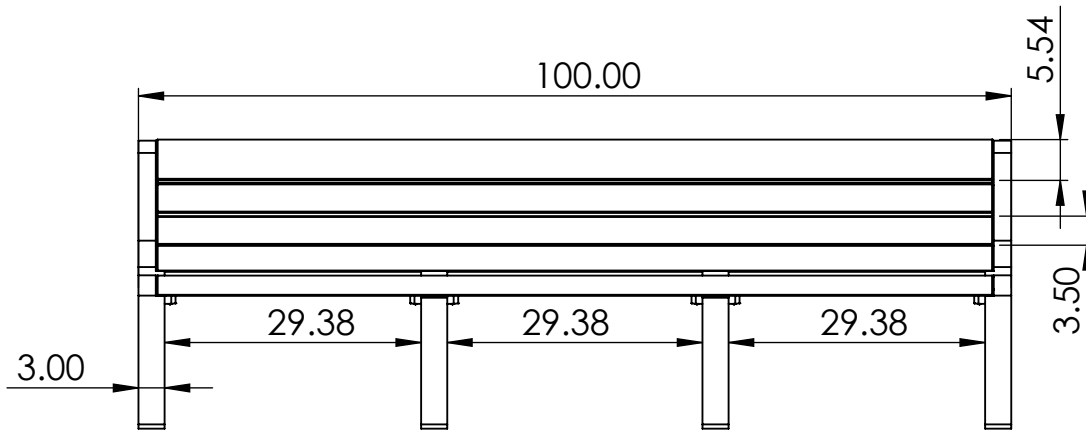
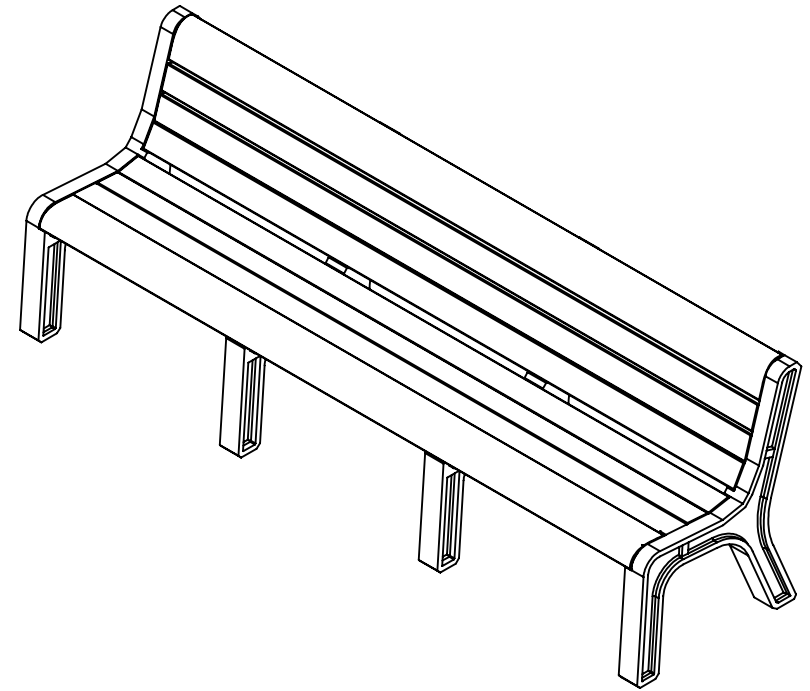
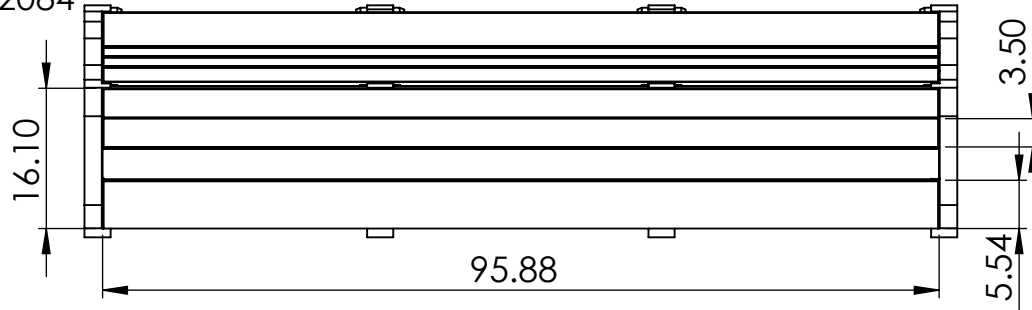

### FRONT

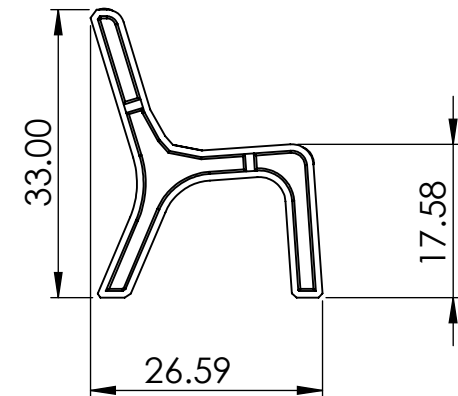

### SIDE

**CONSTRUCTION MATERIALS:**  
Recycled Plastic  
**HARDWARE:**  
Stainless Steel

ALL DIMENSIONS ARE SHOWN IN INCHES