

BENCH INSTRUCTIONS

REV# 1

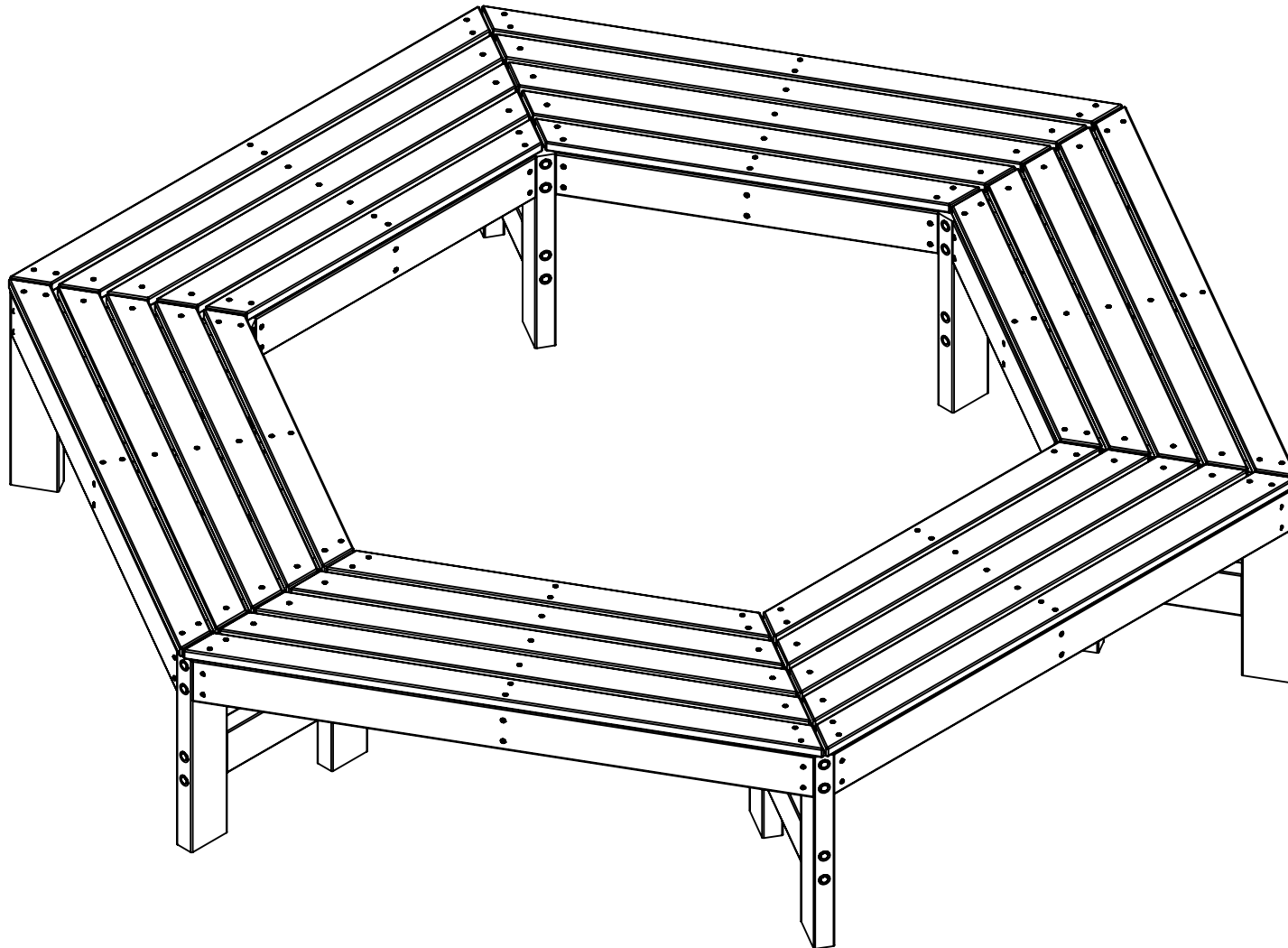

BENCH INSTRUCTIONS

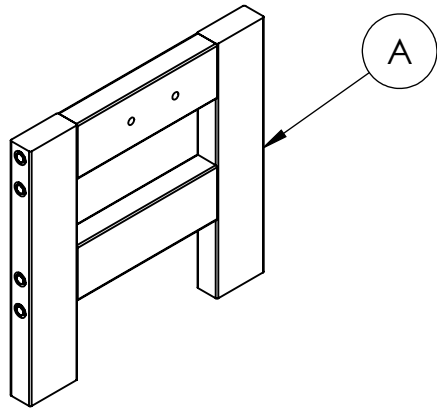

6
Bench End

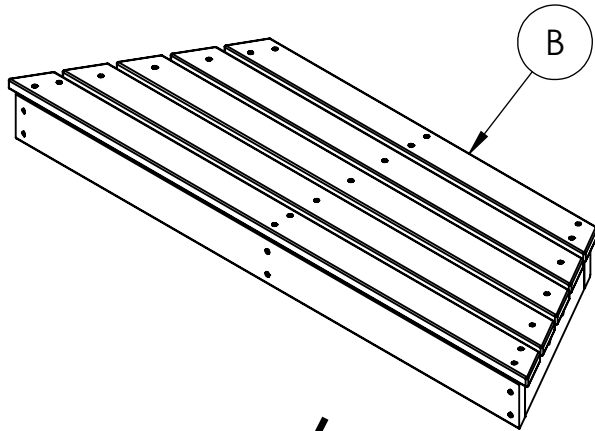

6
Seat Assembly

**REQUIRED TOOLS
(NOT INCLUDED)**
- 5/8" Wrench or Ratchet

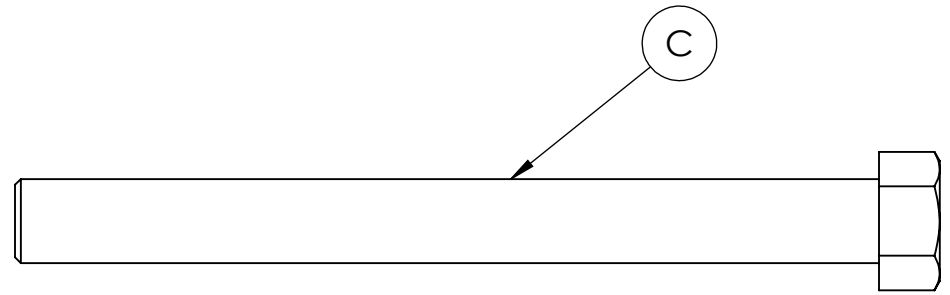

12
7/16 x 4.5" Hex Bolts

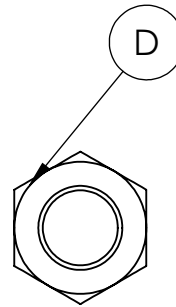

12
7/16" Hex Nuts

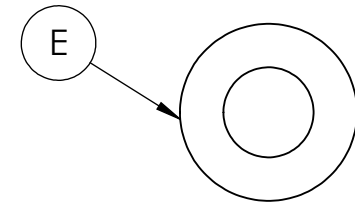

24
7/16" Flat Washer

**NOTE: IT IS IMPORTANT TO KEEP ALL SCREWS LOOSE
DURING ASSEMBLY UNTIL ENTIRE BENCH IS ASSEMBLED**

**HARDWARE &
TOOLS REQUIRED
FOR ASSEMBLY**

3/6

BENCH INSTRUCTIONS

ATTACH BENCH END TO SEAT ASSEMBLY

- Insert two hex bolts (C) with flat washers (E) through one seat assembly (B), a bench end (A) and through a second seat assembly (B)
- Secure with flat washers (E) and hex nuts (D)
- Leave nuts finger tight until a later step

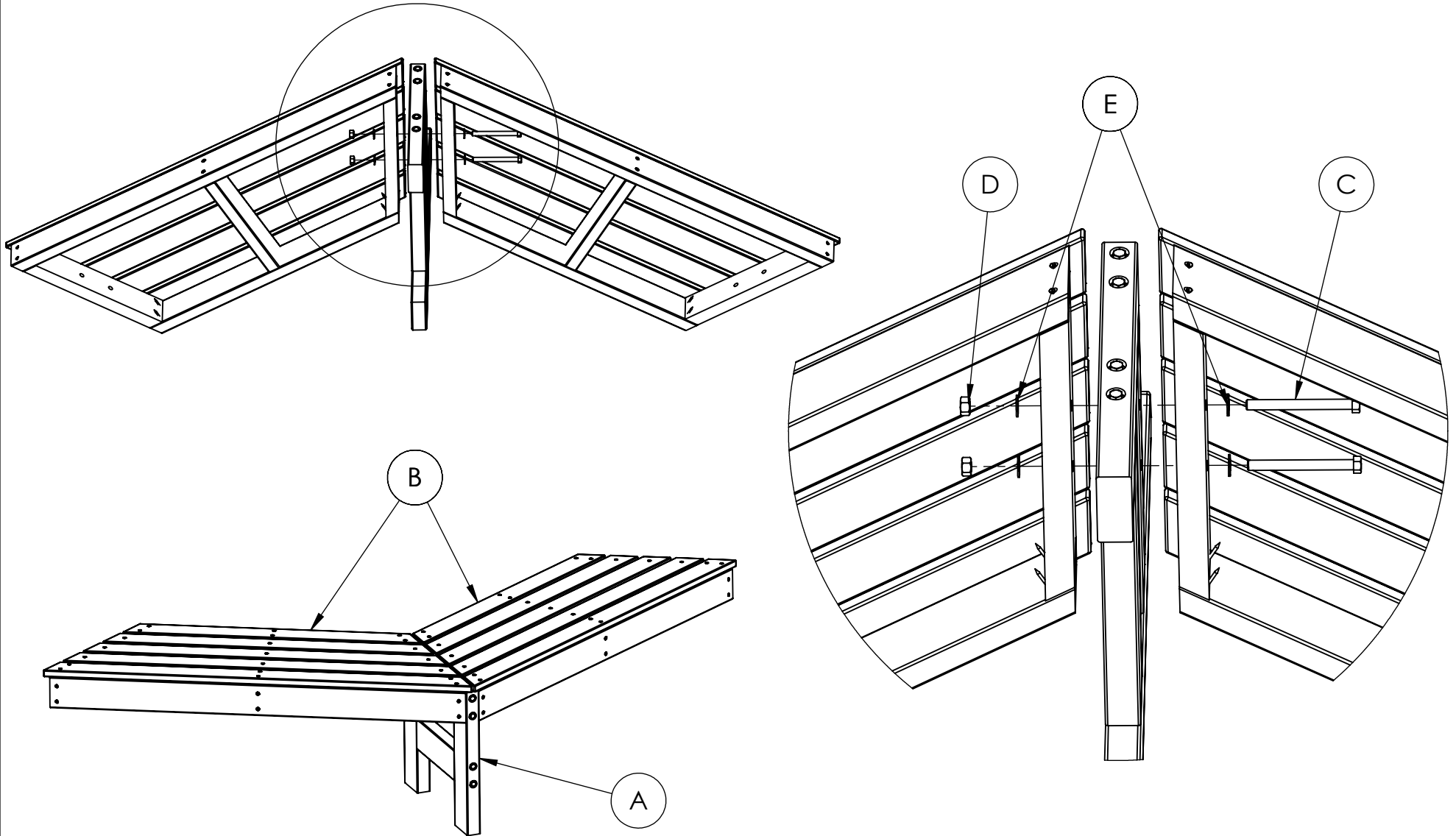

BENCH INSTRUCTIONS

SEATING ASSEMBLY

- Insert two hex bolts (C) with flat washers (E) through the seat assembly (B)
- Add the next bench end (A) to the end of the seat assembly
- Add a seat assembly (B) to the bench end
- Secure with a flat washer (E) and hex nut (D)
- Repeat these steps for all remaining seat assemblies and bench ends

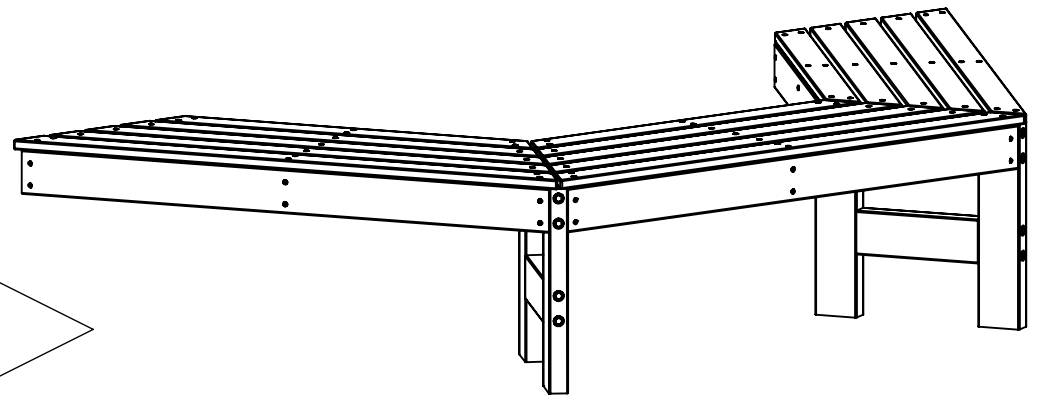
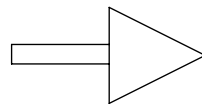
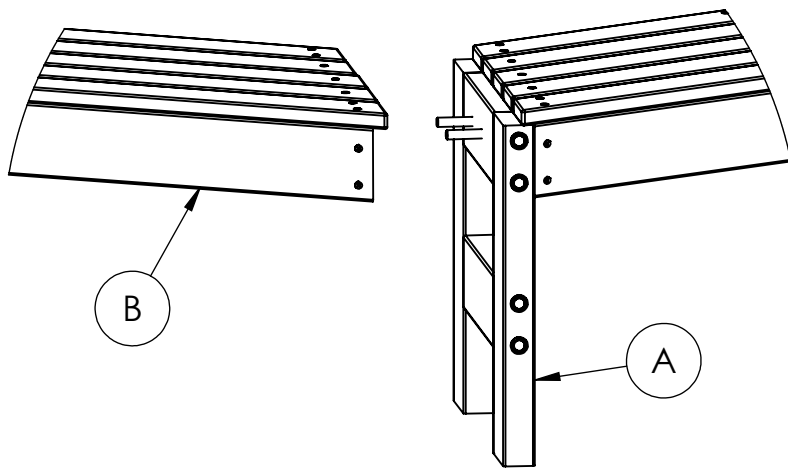
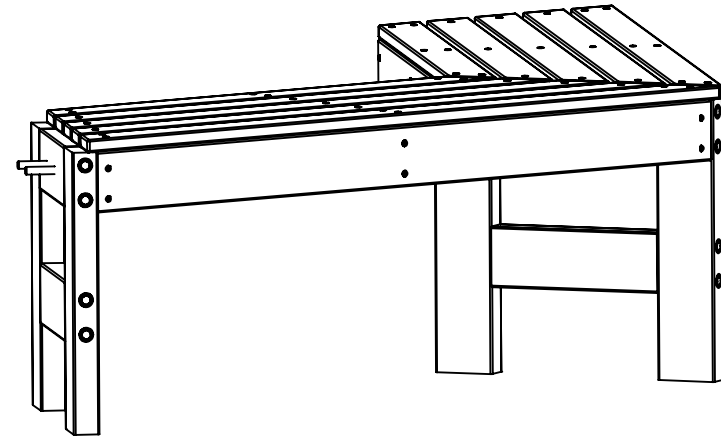
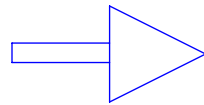
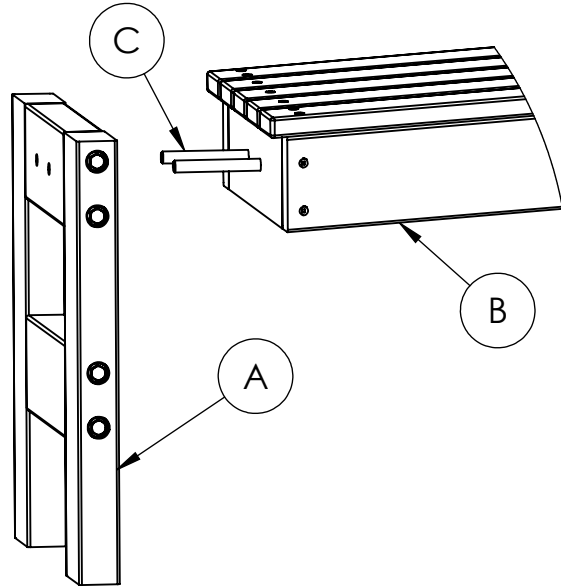

**BENCH
SPECIFICATIONS
BC0635**

